

Name and surname: _____

Grade: _____ Date _____

Learning to calculate with the abacus

session
3



Length: 5 minutes
Material: pencil and colouring pencils

activity 4:

Complete and decorate your design

Trace the dotted lines with the pencil and find out what it is. Afterwards, colour and decorate it as you want.

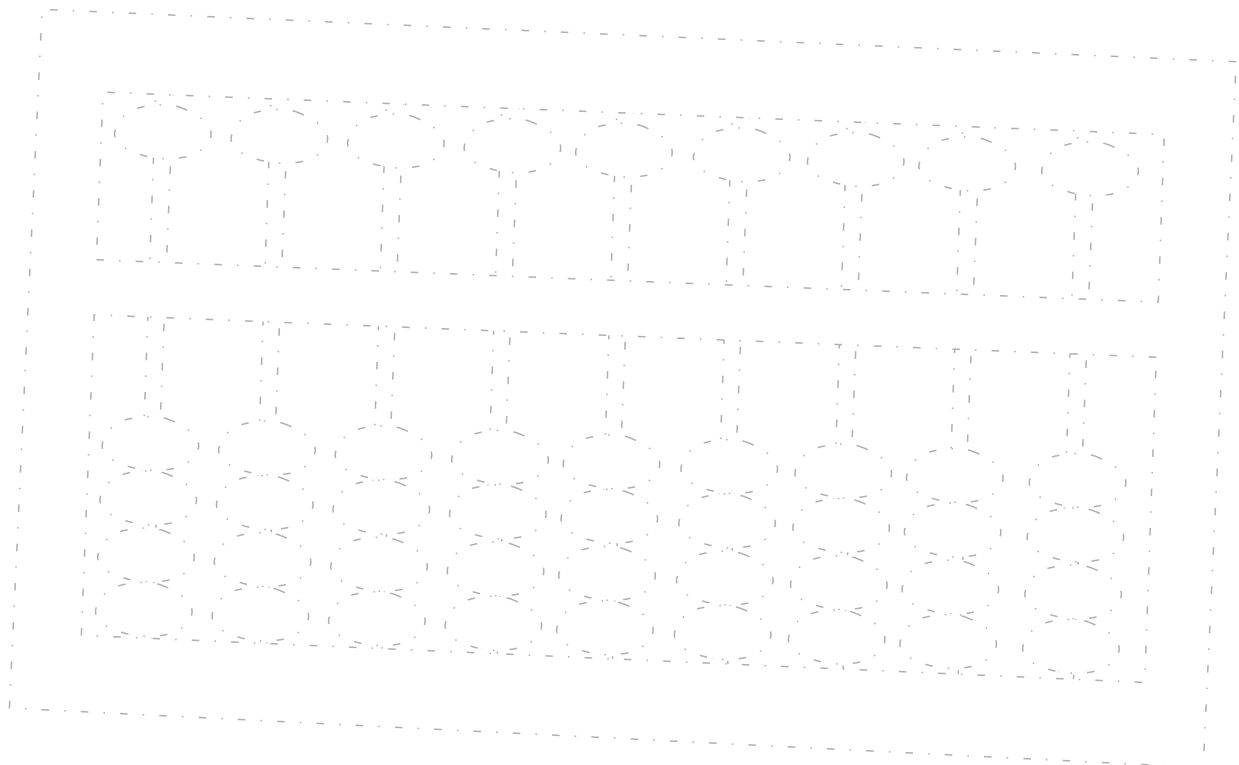

Name and surname: _____

Grade: _____ Date _____

Learning to calculate with the abacus



Length: 15 minutes
Material: pencil

session
3



activity 5:

Parts of the abacus

1. Write in each panel the name of the corresponding part of the abacus.
(TENS - FRAME- UPPER BEAD - LOWER BEADS - UNITS - ANSWER BEAM - HUNDREDS- COLUMNS)
2. Write the value of each bead in the circles.

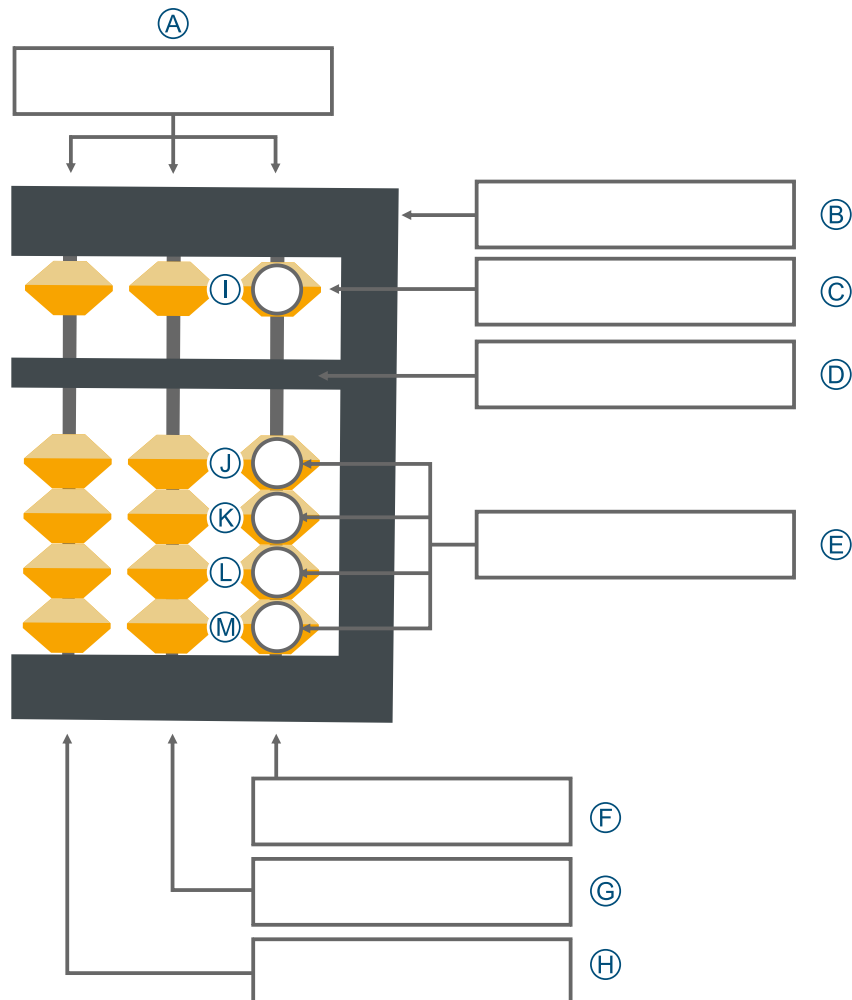

Learning to calculate with the abacus



session
3



Length: 5 minutes
Material: (optional) stickers
Organisation: individual
Content: review the parts of the abacus

activity 4:

Complete and decorate your design

Trace the dotted lines with the pencil and find out what it is. Afterwards, colour and decorate it as you want.

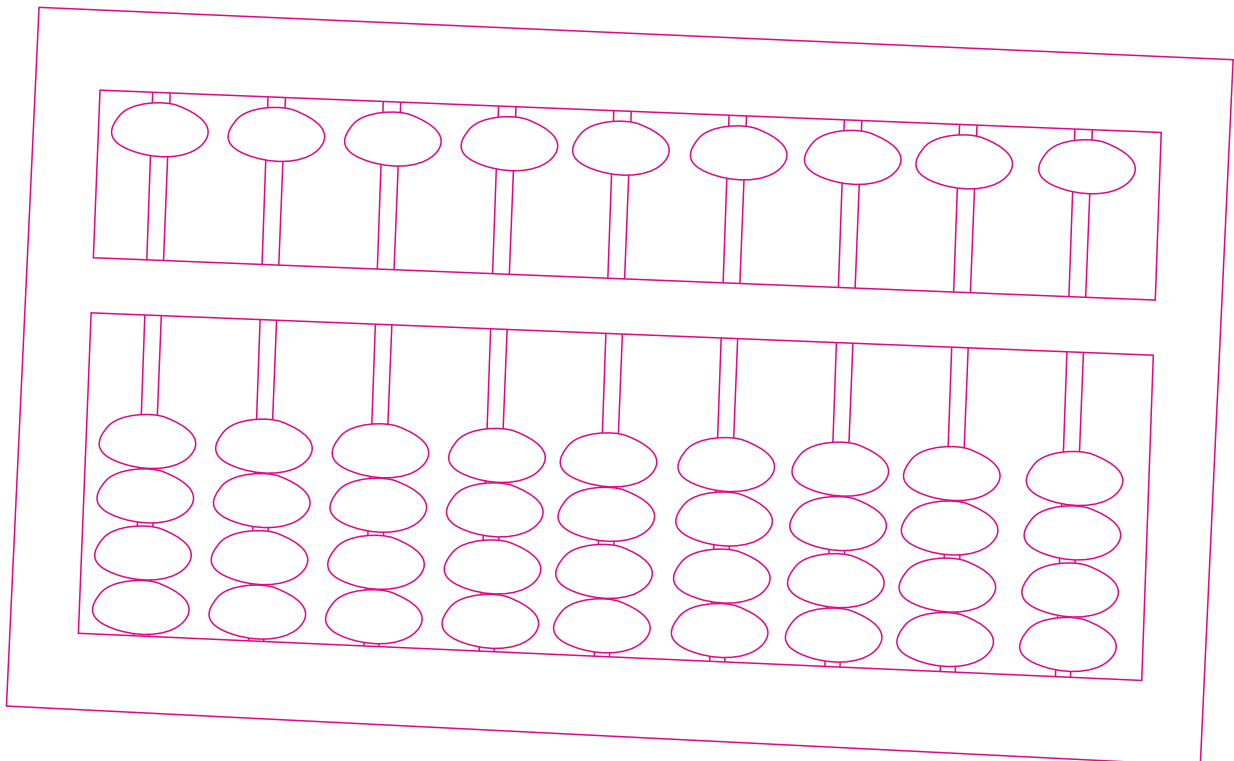

Learning to calculate with the abacus



session
3

Length: 15 minutes

Material: none

Organisation: individual

Content: identifying the parts of the abacus and the value of beads

activity 5:

Parts of the abacus

Information for the teacher

Acknowledging the parts of the abacus, the positional value of the numbers and how to represent quantities with the abacus.

Now, do the activity from the student's practice sheet.

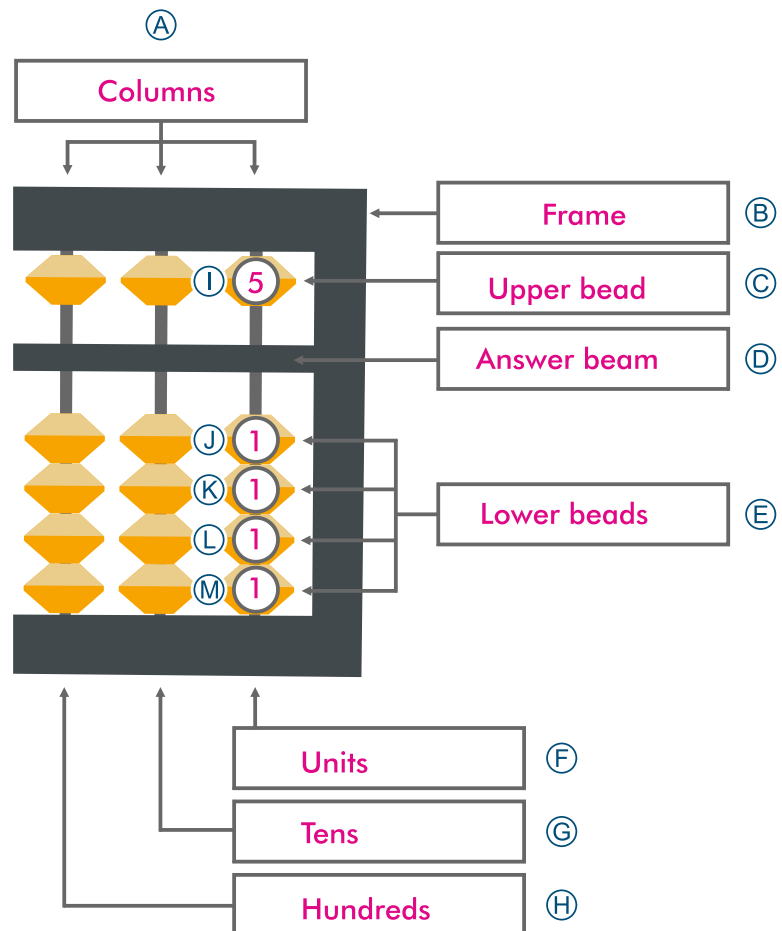



Game 3

Length: 10 min

Happy Monkeys

Main ability practised: Observation.

This game also enhances: Attention & Concentration and Spatial Orientation.

The teacher will draw one of these monkeys in different positions on the whiteboard. The student shall imitate the position the teacher drew the monkey in, then the teacher will draw another monkey so that the child also imitates that position and continues to do the same with other monkeys.

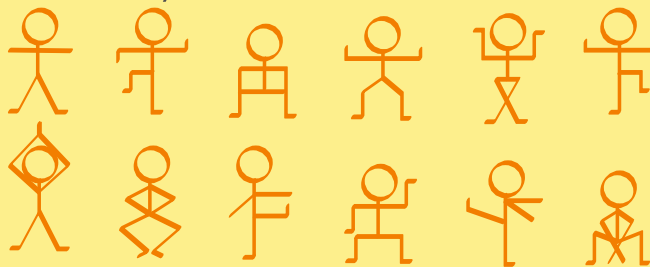

Optional: It is possible to do cards with the positions to represent. These cards will be dealt among the students for them to reproduce the position.

Developed by:



in collaboration with: www.orientacionandujar.es